

## EEL M6.5

# AZ63120001

637nm 12mW

Good optical quality, high stability, stable optical output power, high shock resistance coefficient.

MTTF >20,000 hours, small size and light weight. The optical axis deviation is small, and the measurement accuracy is improved.

M6.5 is a standard common size, which is suitable for initial product development and accelerates the production process.



## Feature

- Common public version, saving development costs
- High stability
- High seismic coefficient

## Application

- Sensor
- Sweeper robot
- Barcode scanning
- SLAM

## Specification

Parameter	Symbol	Min.	Typical	Max.	Unit
CW Optical Power	$P_O$	-	-	12	mW
Operating Current	$I_{OP}$	-	44	55	mA
Operating Voltage	$V_{OP}$	-	2.2	2.5	V
Wavelength at Peak Emission	$\lambda_p$	-	637	645	nm
Operating Temp. Range	$T_{OP}$	-10	-	50	°C
Storage Temp. Range	$T_{STG}$	-40	-	85	°C

## Mechanical Dimensions

### 1. Dimensional Drawing

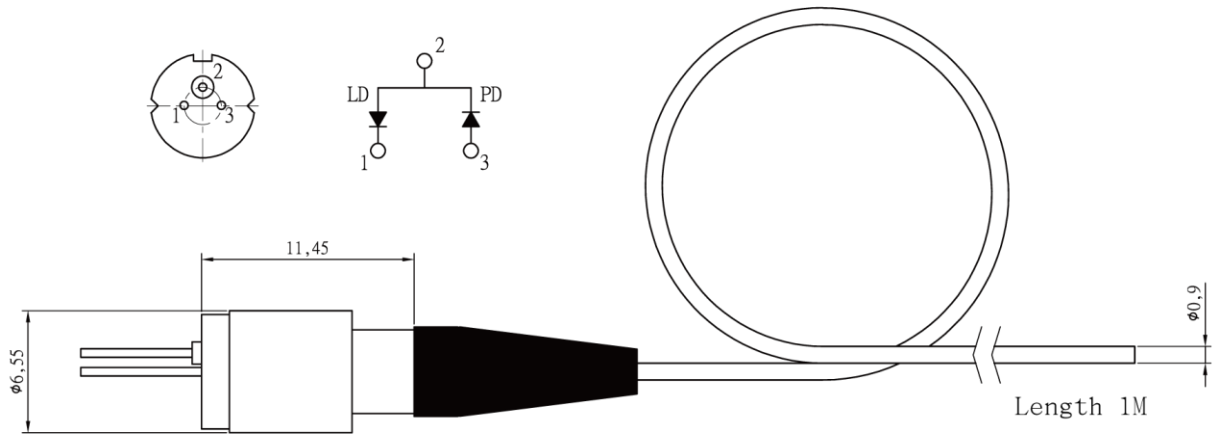

## **[ Cautions ]**

### 1. Absolute maximum ratings

The absolute maximum ratings which must not be exceeded even momentarily have been established for over driving laser operation reason such as COD. Exercise particular caution with respect to the drive voltage supply and static electricity.

### 2. Prevention of surge current and electrostatic discharge (ESD) and surge stress

Laser diode is sensitive device to ESD and surge, so even an extremely short time, Laser diode damaged with the strong light emitted. Use the power supply that was designed not to exceed the optical power output specified at the absolute maximum ratings.

We advise taking the following protective measures:

- Ground the device and circuits.
- When working with laser diodes wear anti-static clothing.
- Grounded wrist straps should always be worn while working with laser diodes.
- Use anti-static containers for transport and storage.
- Laser diode deterioration and damage can occur due to excessive current spikes when the power is turned on or off.

Design circuits to avoid the generating of excessive current spikes

### 3. Soldering

When soldering, please give attention to the mechanical stress and the temperature. Temperature of die-pad portion should be less than 160°C. It is recommended to radiate heat by putting heat sink on the package.

**Soldering temperature and time : Iron temperature less than 180°C within 3sec (leads only)**

### 4. Eye Safety

When the laser diode is in operation, looking into laser beam directly by naked eyes, even looking into through a lens, microscope, or optical fibers, may cause severe damage to human eyes. For observing laser beams, using safety goggles is recommended.

#### **| LECC TECHNOLOGY CO., LTD.**

2F No.2, Ziqiang 3rd Rd., Zhongli Dist., Taoyuan City, 320023, Taiwan.  
TEL | 03 4511967 VAT Number | 16708380  
FAX | 03 4511923 Email | sales@lecc.com.tw

#### **| SHANGHAI LECC OPTO CO., LTD.**

No.1939, Da Ye Rd., Feng-Xian Dist., Shanghai City, 201402, China.  
TEL | 021 57407400 TAX Number | 913100007630197034  
FAX | 021 57407403 Email | sales@lecc.com.tw